

# HARD WIRED LEVEL CONTROL

## SUPPLY CABLE WIRE COLOR & OPERATION

EQD Pin #	Wire Color	Function
1	Brown	Manual Run
2	Red	L1
3	Black	L2 or Neutral
4	Green w/ Yellow Stripes	Ground
5	Yellow	Alarm Power Feed
6	Blue	Alarm Power Return

Supply Cable

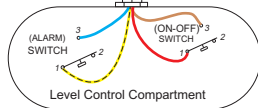

## HARD WIRE OPTION

Alarm Yellow and Blue wires go to the alarm panel only Motor Control Red and Brown wires go to both alarm panel and motor contactor

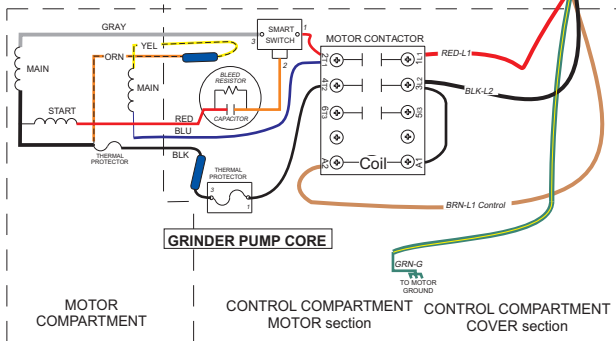

NA0036P12 C  
 120 Volt 60 Hz  
 Control Wiring Tag

eone